

INSTRUCTION MANUAL

EB-270DS

Swivel Head Metal Cutting Band Saw (415V) 245 x 160mm (W x H) Rectangle



B064

PLANT SAFETY PROGRAMMÉ NEW MACHINERY HAZARD IDENTIFICATION, ASSESSMENT & CONTROL

Stock Code: B064

Description: Metal Cutting Bandsaw

Model: EB-270DS

Brand:

HAFCO

Developed in Co-operation Between A.W.I.S.A and Australia Chamber of Manufactures
This program is based upon the Australian Worksafe Standard for Plant(NOHSC:1010-1994)



Item No.	Hazard Identification	Hazard Assessment	Risk Control Strategies (Recommended for Purchase / Buyer / User)
A	ENTANGLEMENT	HIGH	Eliminate, avoid loose clothing / Long hair etc.
B	CRUSHING	LOW	Secure & support Long / heavy material
C	CUTTING, STABBING, PUNCTURING	MEDIUM	Blade guards should always be in the closed position before starting machine. Blade guide system should be adjusted to suit material width. Wear gloves when changing blades. Isolate main power switch before changing blade, cleaning or adjusting. If blade breaks do not open door until both wheels have stopped. Check blade tracking before starting.
D	SHEARING	MEDIUM	Make sure all guards are secured shut when machine is on. Isolate power to machine prior to changing belts or maintenance.
F	STRIKING	LOW	Support long heavy jobs and stand clear of offcuts. Stand clear of machine when in operation. Remove all loose objects around moving parts. Wear safety glasses
H	ELECTRICAL	MEDIUM	All electrical enclosures should only be opened with a tool that is not to be kept with the machine. Machine should be installed & checked by a Licensed Electrician.
O	OTHER HAZARDS, NOISE.	LOW	Wear hearing protection as required.

Plant Safety Program to be read in conjunction with manufactures instructions



ABN 96 000 286 957

"THE JUNCTION" 2 WINDSOR ROAD, NORTHMEAD NSW 2152
Phone (02) 9890 9111 Fax (02) 9890 3888

Authorised and signed by: 
Safety officer: 
Manager:

Date: Mar-02

Contents

Contents

Chapter 1

ACCIDENT PREVENTION AND SAFETY REGULATION

1.1 Advice for the operator.....	2
1.2 The electrical equipment according to European Standard "CENELEC EN 60 204-1" (1992).....	2
1.3 Emergencies according to European Standard "CENELEC EN 60 204-1 (1992)".....	2

Chapter 2

MACHINE DIMENSIONS TRANSPORT INSTALLATION DISMANTLING

2.1 Machine dimensions.....	2
2.2 Assembling the Saw and the Base.....	2
2.3 Minimum requirements for housing the machine...3	
2.4 Anchoring the machine.....	3
2.5 Instructions for assembly of the loose parts and accessories.....	3
2.6 Disactivation of machine.....	3
2.7 Dismantling.....	3

Chapter 3

THE MACHINE'S FUNCTIONAL PARTS

3.1 The saw arm.....	3
3.2 Controls.....	4
3.3 Vice adjustment.....	4
3.4 Cutting angle adjustment.....	5
3.5 The base.....	5
3.6 Saw frame return stroke-limiting device.....	5
3.7 The operation cycle.....	5

Chapter 4

ADVICE ON USING YOUR BANDSAW

4.1 Recommendations and advice for using the machine.....	6
--	---

Chapter 5

ADJUSTING YOUR MACHINE

5.1 Blade tension assembly.....	7
5.2 Adjusting the blade guide.....	7
5.3 Changing the blade.....	7
5.4 Adjusting the blade to the flywheels.....	8

Chapter 6

ROUTINE AND SPECIAL MAINTENANCE

6.1 Daily maintenance.....	8
6.2 Weekly maintenance.....	8
6.3 Monthly maintenance.....	8
6.4 Six-monthly maintenance.....	8
6.5 Maintenance of other machine parts.....	8
6.6 Oils for lubricating coolant.....	8
6.7 Oil disposal.....	9
6.8 The gear box.....	9
6.9 Special maintenance.....	9

Chapter 7

TECHNICAL CHARACTERISTICS

7.1 Table of cutting capacity and technical details.....	9
--	---

Chapter 8

MATERIAL CLASSIFICATION AND CHOICE OF TOOL

8.1 Definition of materials.....	10
8.2 Selecting blade.....	10
8.3 Teeth pitch.....	10
8.4 Cutting and advance speed.....	10
8.5 Blade running-in.....	10
8.6 Blade structure.....	10
8.7 Blade type.....	11

Chapter 9

NOISE TESTS.....	11
------------------	----

Chapter 10

WIRING DIAGRAM.....	12
---------------------	----

Chapter 11

TROUBLESHOOTING

11.1 - Blade and cut diagnosis.....	13
11.2 - Electrical components diagnosis.....	17

Chapter 12

MACHINE COMPONETS

12.1 Parts list.....	18
12.2 Explosion drawings.....	21

1 ACCIDENT PREVENTION AND SAFETY REGULATION

This machine has been designed to comply with national and community accident-prevention regulations. Improper use and/or tampering with the safety devices will relieve the manufacturer of all responsibility.

1.1 Advice for the operator

- Check that the voltage indicated on machine motor is the same as the line voltage.
- Check the efficiency of your electric supply and grounding system; connect the power cable of the machine to the socket and the ground lead (yellow-green in color) to the grounding system.
- When the saw frame is in suspended mode (or raised) the blade must not move.
- Only the blade section used for cutting must be kept unprotected. To remove guards operate on the adjustable head.
- It is forbidden to use the machine without its shields
- Always disconnect the machine from the power socket before blade change or carrying out any maintenance job, even in the case of abnormal machine operation.
- Always wear suitable eye protection.
- Never put your hands or arms into the cutting area while the machine is operating.
- Do not shift the machine while it is cutting.
- Do not wear loose clothing like: shirts with sleeves that are too long, gloves that are too big, bracelets, chains or any other object that could get caught in the machine during operation. Tie back long hair.
- Keep the area free of equipment, tools, or any other object.
- Perform only one operation at a time. Never have several objects in your hands at the same time. Keep your hands as clean as possible.
- All internal operations, maintenance or repairs, must be performed in a well-lit area or where there is sufficient light from extra sources so as to avoid the risk of even slight accidents

1.2 The electrical equipment according to European Standard "CENELEC EN 60 204-1" which assimilates, with some integrating modifications, the publication "IEC 204-1 (1992)"

- The electrical equipment ensures protection against electric shock as a result of direct or indirect contact. The active parts of this equipment are housed in a box to which access is limited by screws that can only be removed with a special tool; the parts are fed with alternating current as low voltage (24V). The equipment is protected against splashes of water and dust.
- Protection of the system against short circuits is ensured by means of rapid fuses and grounding; in the event of a motor overload, protection is provided by a thermal probe.
- In the event of a power cut, the specific start-up button must be reset.
- The machine has been tested in conformity with point 20 of EN 60204

1.3 Emergencies according to European Standard "CENELEC EN 60 204-1 (1992)"

- In the event of incorrect operation or of danger conditions, the machine may be stopped immediately by pressing the red mushroom button.
 - The casual or voluntary removal of the blade cover of the flywheels causes the stepping-in of a interlock switch that automatically stops all machine functions.
 - In case blade breakage, the tension release microswitch disconnects all machine functions.
- NOTE: Resetting of machine operation after each emergency stop requires specific restart button.

2 MACHINE DIMENSIONS TRANSPORT INSTALLATION DISMANTLING

2.1 Machine dimensions

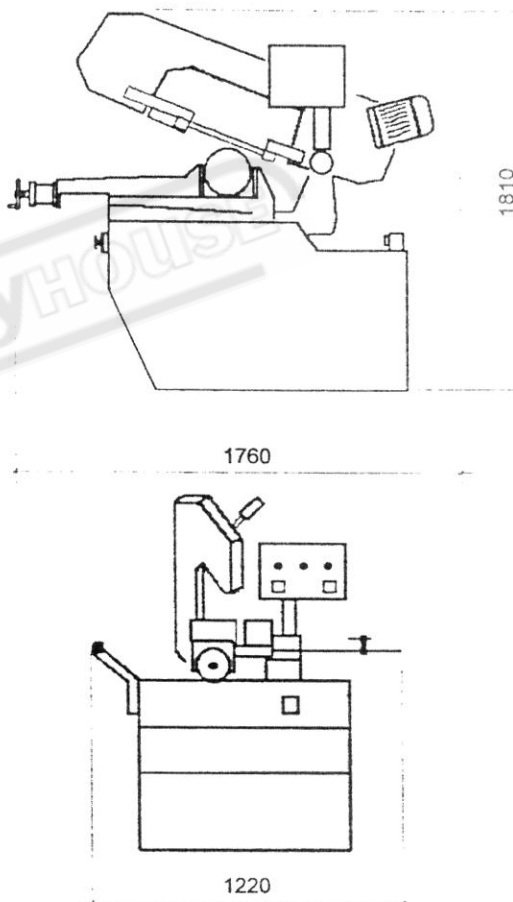

2.2 Assembling the Saw and the Base

- Join panels A, B, and C by inserting tenon into mortise as shown in circle diagram 1 and 2.
- Fasten bottom panel D into the joined panels A, B, and C using set screws that are provided
- Attach panel F to panel C with provided set screws.
- Attach control box with two provided set screws.
- Mount the saw unit on the base as shown in drawing 5.
- Fasten the saw unit to the base with provided set screws.

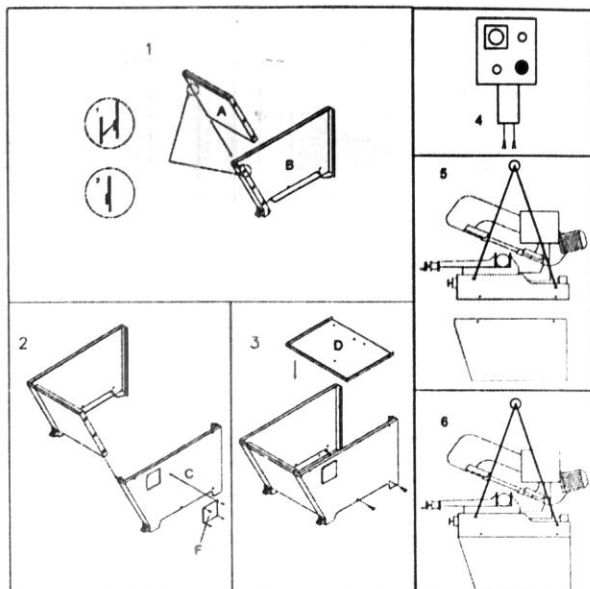

If the machine needs to be moved in its own packing, use a forklift truck or sling it with straps as illustrated in drawing 6 above.

2.3 Minimum requirements for housing the machine

- Main voltage and frequency must comply with the machine's motor requirements.
- Environment temperature should fall within $-10\text{ }^{\circ}\text{C}$ to $+50\text{ }^{\circ}\text{C}$.
- Relative humidity cannot be over 90%.

2.4 Anchoring the machine

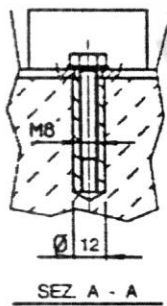

Position the machine on a firm cement floor, maintaining, at the rear, a minimum distance of 800 mm from the wall; anchor it to the ground as shown in the diagram, using screws and expansion plugs or tie rods sunk in cement, ensuring that it is sitting level.

2.5 Instructions for assembly of the loose parts and accessories

Fit the components supplied:

Detail 1 Mount bar-stop rod

Detail 2 Mount and align the roll-supporting arm as per the counter-vice table.

2.6 Disactivation of machine

- If the sawing machine is to be out of use for a long period, it is advisable to proceed as follows:

- 1) Detach the plug from the electric supply panel
- 2) Loosen blade
- 3) Release the arch return spring

- 4) Empty the coolant tank
- 5) Carefully clean and grease the machine
- 6) If necessary, cover the machine.

2.7 Dismantling (due to deterioration and/or obsolescence)

General rules

If the machine is to be permanently demolished and/or scrapped, divide the material to be disposed of according to type and composition, as follows:

- 1) Cast iron or ferrous materials, composed of metal alone are secondary raw materials, so they may be taken to an iron foundry for re-smelting after having removed the contents (classified in point 3).
- 2) Electrical components, including the cable and electronic material (magnetic cards, etc.), fall within the category of material classified as being assimilated to urban waste according to the laws of your local, state, or federal government, so they may be set aside for collection by the public waste disposal service;
- 3) Old mineral and synthetic and/or mixed oils, emulsified oils and greases are considered hazardous or special refuse, so they must be collected, transported and disposed of at a special waste disposal service.

NOTE: The standards and legislation concerning refuse is in a constant state of evolution, therefore is subject to changes. The user must keep informed of the regulations at the time of disposal as these may differ from those described above.

3 THE MACHINE'S FUNCTIONAL PARTS

3.1 The saw arm

Machine part consisting of drive members (gear motor or variable speed motor, flywheels), tightening and guide (blade tightening slide, blade guide blocks) of tool.

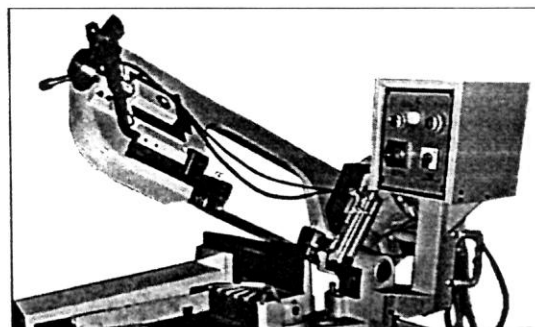

3.2 Controls

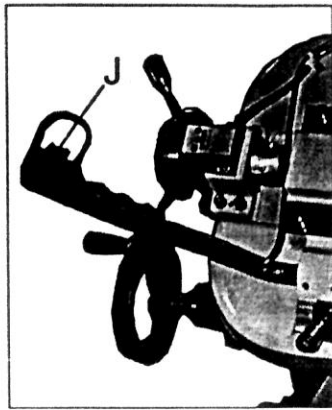
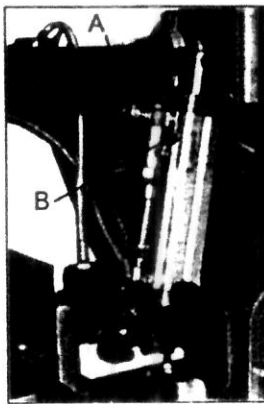

- A. Hydraulic Flow control valve
- B. Hydraulic regulation valve
- J. Trigger Switch

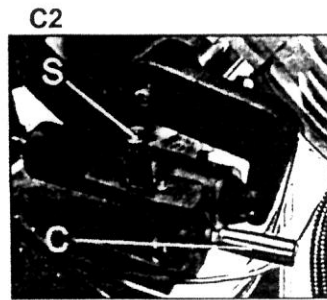
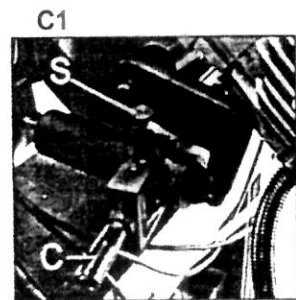
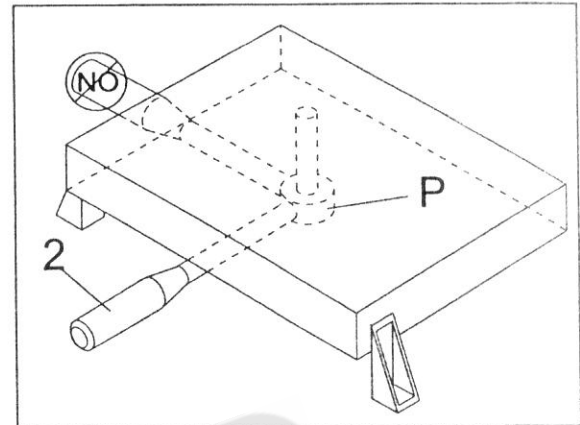
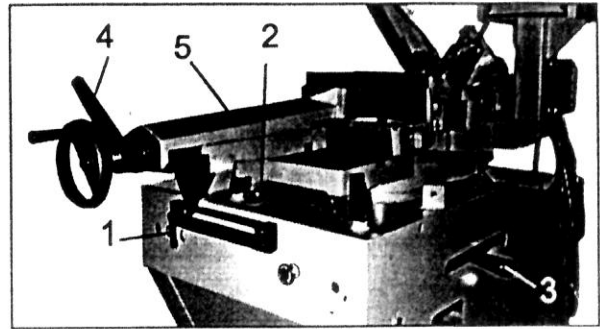

- C. Fork handle
- S. Spring knob
- C1. Manual position
- C2. Auto position

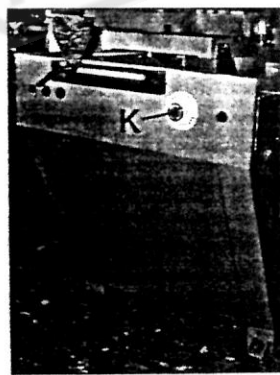
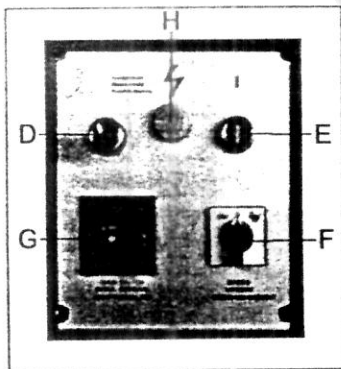

- D. Manual/Auto selector
- E. Start/Reset push button
- F. Speed selector
- G. Main connect switch
- H. Indicator light
- K. Emergency push button

3.3 Vice adjustment

- The device does not require any particular adjustment; in case of excess play of the sliding guide, tighten slide screw more.

To move the vise in either direction, the vise jaw must be unlocked at two points.

- Release the track support by turning handle (1) counter-clockwise.
- Release the vise by moving the lever (2) to the left.
- The vise (5) may now be moved to right position (7) or left position (6) by pushing it with one hand on the vice and the other hand on the track handle (1).
- Once in position, move the lever (2) to the right to lock it into position. If the lever (2) is not between the vice/bed mounts and facing the user, then the vise will not be able to lock. If the vice lever (2) has gone beyond or is obstructed by a vice/bed mount, then use the following procedures.
- Adjust the lever (2) by grasping at the pivot point (P) and lowering it, which may assist in the adjustment. The lever can now be freely rotated into a more convenient position. Some movement of the vice jaw may be required. Raise the lever (2) then move to the right to lock.
- Lock the track support (1) by turning handle clockwise.

Clamping the Work Piece

- Place work piece between the jaws.
- Use the hand wheel to approach the vice jaws to the work piece, leaving 3-4mm of space. Lock down work piece and raise the lever (4). Push start button (E). When the cutting cycle is finished, release vice by lowering lever (4). Upon releasing the lever (4), the vice jaw will open to the same distance that was set initially. This allows for rapid loading of same size material.

3.4 Cutting angle adjustment

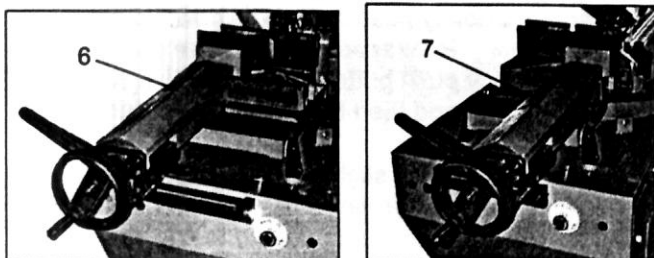

Cutting at angles

- Using the right side, angles can be cut up to 60 degrees. This requires that vice jaw to be set on the left side (6). Use the procedures for 3.2 *Vice Adjustment* to place it in left side position.
- Using the left side, angles can be cut up to 45 degrees. This requires the vice jaw to be set on the right side (7). Use the procedures for 3.2 *Vice Adjustment*, to place it in right side position.
- Unlock lever (3) and use the handle under the control box to rotate the saw frame arm until you reach mechanical stop and check if the index corresponds to 45 degrees; if not, operate on the set screws to make measures meet.

3.5 The base

- A structure supporting the SAW ARM (revolving arm for gradual cutting and respective blocking system), the VICE, the BAR STOP, the ROLLER for the support of the material. The base houses the cooling liquid TANK and PUMP.

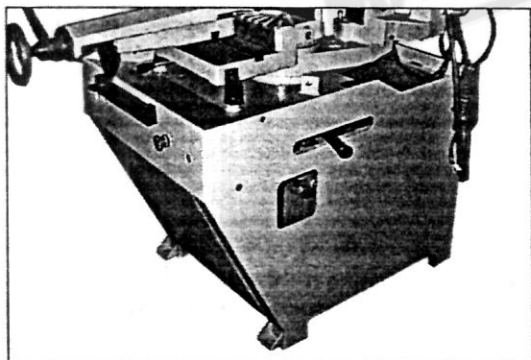

3.6 Saw frame return stroke-limiting device

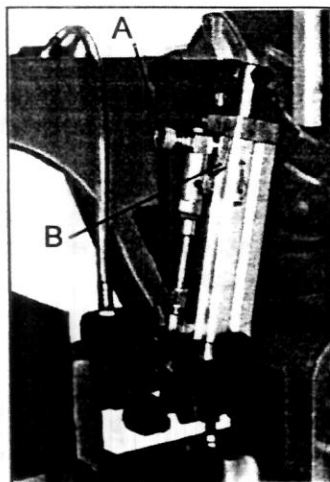

The hydraulic cylinder is ideal for the cutting of thin or STAINLESS STEEL section bars, that determines a constant lowering and consequently a good efficiency of the blade throughout the work phase. By adjusting the flow control valve (A), this device can be accommodated to the different situations and applications. Defectiveness in the control of the lowering may be caused by the drop in braking power of the device due to the long-term blowby of the braking fluid.

3.7 The operation cycle

Before operating, all the main organs of the machine must be set in optimum conditions

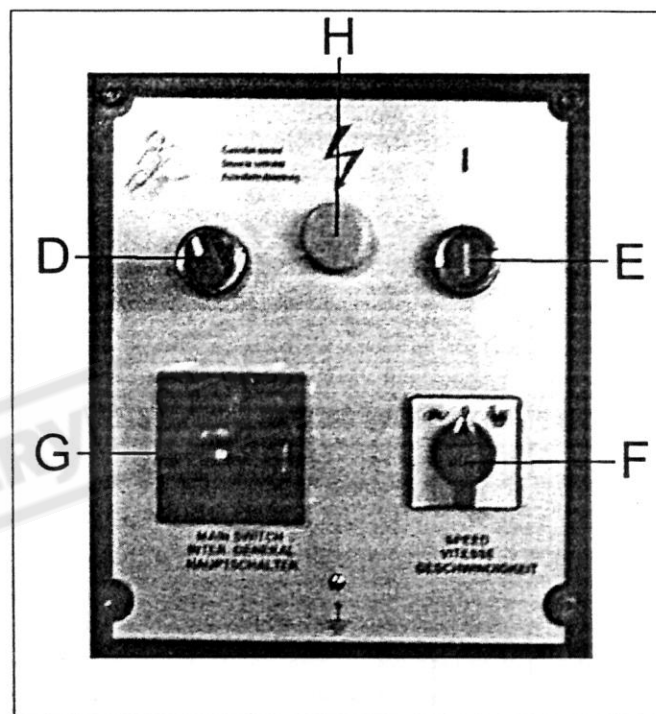

Operation Procedure:

A. Trigger switch operation

- Close the hydraulic flow control valve (A) by turning the valve clockwise all the way to the end.
- Raise the saw arm.
- Lift the spring knob (S) to release the pin from its slot. This will free the fork handle (C). Move the handle to the manual position (C1). Lift the spring knob (S) and secure its pin into its slot.
- Use manual/auto selector (D) to select handle icon.
- Select cutting speed by turning speed selector (F). Turtle is low speed, rabbit is high speed, and 'O' is neutral.
- Turn main connect switch (G) to the ON position. Check that the indicator light (H) is on.
- Load work piece and clamp it properly.
- Fully open the hydraulic flow regulation valve (B) by turning the valve counter-clockwise all the way to the end.

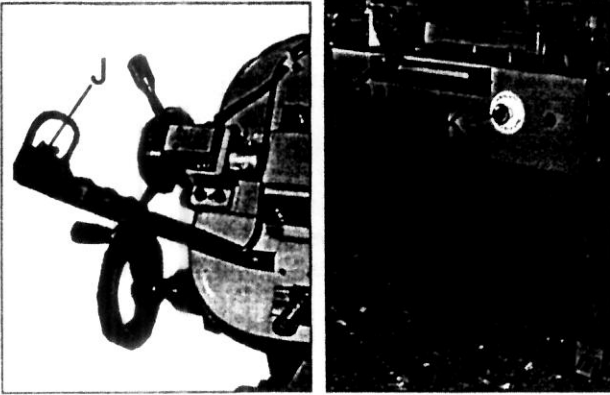

- Press trigger switch (J) to start operation.
- If cutting pipe with thin walls, reduce the saw arm descent rate by adjusting the flow control valve (A)
- Press the emergency push button (K) down to shut off all functions. To release the emergency push button rotate the mushroom shaped button (K) clock-wise. The button will pop up and then the cutting cycle can be restarted.
- In general, start cuts by slightly turning hydraulic flow control valve (A) counter-clockwise from 2 to 3 to control the saw arm descent rate. If the arm descends too quickly, turn the hydraulic flow regulation valve (B) clockwise all the way back to stop its descent. A saw arm dropping too quickly can cause the blade to stall on the work piece and the machine will shut off. Push down on emergency push button (K) to immediately stop all machine functions.

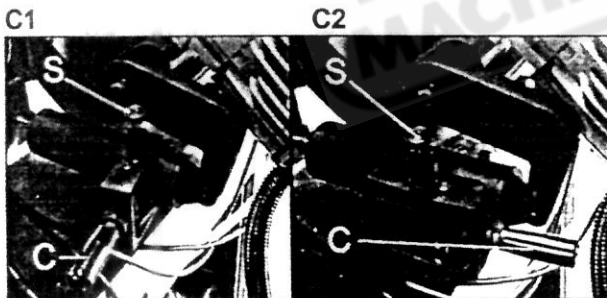

B. Auto cutting operation

- Close the hydraulic flow control valve (A) by turning the valve clockwise all the way to the end.
- Raise the saw arm.
- Lift the spring knob (S) to release the pin from its slot. This will free the fork handle (C). Move the handle to the auto position (C2). Lift the spring knob (S) and secure its pin into its slot.
- Use manual/auto selector (D) to select auto.
- Select cutting speed by turning speed selector (F). Turtle is low speed, rabbit is high speed, and 'O' is neutral.
- Turn main connect switch (G) to the ON position. Check that the indicator light (H) is on.
- Load work piece and clamp it properly.
- Press start/reset button (E) to start machine. Check that the blade is running in the correct direction.
- Slightly pull the saw arm down to get rid of air bubbles from the hydraulic cylinder.
- Adjust hydraulic flow control valve (A) by slightly turning the valve counter-clockwise to let saw arm

descend and start cutting.

- Press the emergency push button (K) down to shut off all functions. To release the emergency shut off rotate emergency push button (K) clock-wise. The button will pop up and then the cutting cycle can be restarted.
- In general, start cuts by slightly turning hydraulic flow control valve (A) counter-clockwise from 2 to 3 to control the saw arm descent rate. If the arm descends too quickly, turn hydraulic flow regulation valve (B) clockwise all the way back to stop its descent. A saw arm dropping too quickly can cause the blade to stall on the work piece and the machine will shut off. Push down on emergency push button (K) to immediately stop all machine functions.

BLADE CUTTING DIRECTION

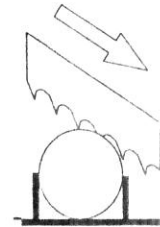

4 ADVICE ON USING YOUR BANDSAW

4.1 Recommendations and advice for using the machine

The machine has been designed to cut metal building materials, with different shapes and profiles, used in workshops, turner's shops and general mechanical structural work,

Only one operator is needed to use the machine, that must stand as shown in the picture.

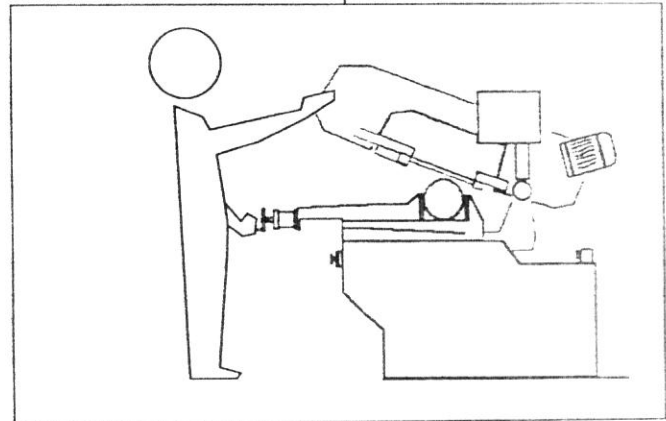

- Before starting each cutting operation, ensure that the part is firmly clamped in the vice and that the end is suitably supported.
- These figures below show examples of suitable clamping of different section bars, bearing in mind the cutting capacities of the machine in order to achieve a good efficiency and blade durability.

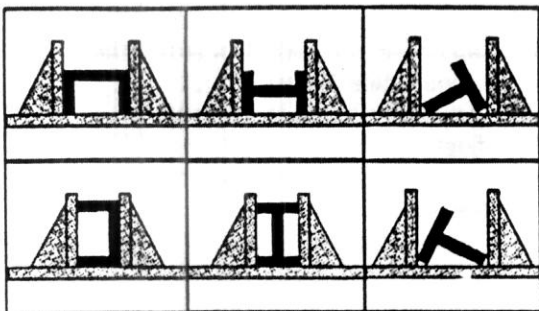

- Do not use blades of a different size from those stated in the machine specifications.
- If the blade gets stuck in the cut, release the running button immediately, switch off the machine, open the vice slowly, remove the part and check that the blade or its teeth are not broken. If they are broken, change the tool.
- Before carrying out any repairs on the machine, consult the dealer.

5 ADJUSTING YOUR MACHINE

5.1 Blade tension assembly

The ideal tension of the blade is achieved rotating the handwheel until it the microswitch, that actuates the operation of the machine is actuated

WARNING: the position of this switch is factory set during inspection, after having tightened the blade on the lengthening values indicated by its manufacturer as per specific dimensions set with the help of a special instrument. When replacing the blade, if the thickness and the width differ, it will be necessary to correct the projection of the switch. For this purpose we suggest to strictly select blades having the same features as mounted originally.

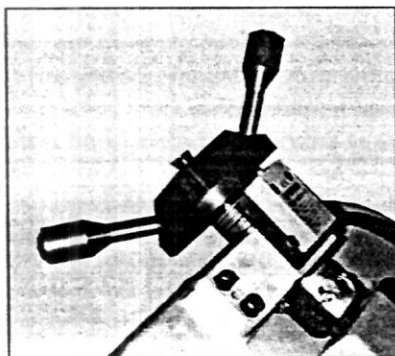

5.2 Adjusting the blade guide

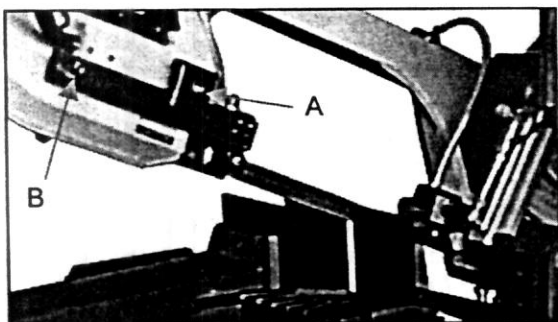

- Disconnect the machine from the power source.
- Use a Hex. Wrench to loosen Hex. Socket screw (A)

- on the square lock plate.
- Hold the handle (B) and slide blade guide block as close as possible to the material without interfering with the cut
- Tighten the Hex. Socket screw (A).
- Reconnect the machine to power source.

Blade guide blocks

The blade is guided by means of adjustable pads set in place during inspection as per the thickness of the blade with minimum play as shown in the figure.

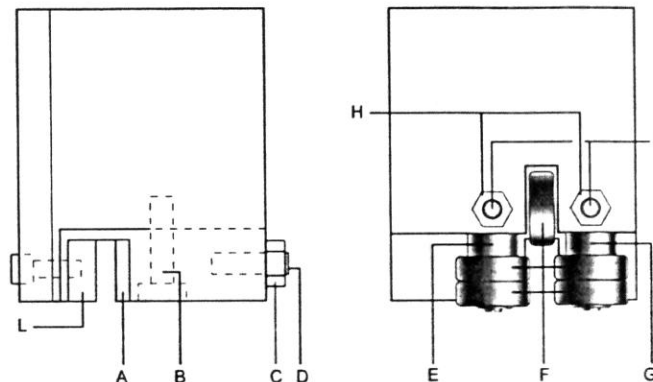

In case the blade needs to be replaced, make sure to always install 0.9mm thick blades for which the blade guide pads have been adjusted. In the case of toothed blades with different thicknesses adjustment should be carried out as follows:

- Loosen nut (C), screw (B) and loosen dowel (D) widening the passage between the pads.
- Loosen the nuts (H) and the dowels (I) and rotate the pins (E - G) to widen the passage between the bearings (F).
- To mount the new blade: place the pad (A) on the blade, loosening the dowel, allow a play of 0.04 mm for the sliding of the toothed blade, lock the relative nut and screw (B), Rotate the pins (E - G) until the bearings rest against the blade as indicated in the figure and then secure the dowels (I) and nut (H).
- Make sure that between the blade and the upper teeth of the pad (L) this is at least 0.2 - 0.3 mm of play; if necessary, loosen the screws that fasten the blocks and adjust accordingly.

BEFORE PERFORMING THE FOLLOWING OPERATIONS, THE ELECTRIC POWER SUPPLY AND THE POWER CABLE MUST BE COMPLETELY DISCONNECTED.

5.3 Changing the blade

To change the blade:

- Lift the saw arm.
- Loosen the blade with the handwheel, remove the mobile blade-guard cover, open the flywheel guards and remove the old blade from the flywheels and the blade guide blocks.
- Assemble the new blade by placing it first between the pads and then on the race of the flywheels, paying particular attention to the cutting direction of the teeth.
- Tension the blade and make sure it perfectly fits inside the seat of the flywheels.

- Assemble the mobile blade-guide end, the flywheel guard, and fasten it with the relative knobs. Check that the safety microswitch is activated otherwise when electric connection will be restored the machine will not start.

5.4 Adjusting the blade to the flywheels

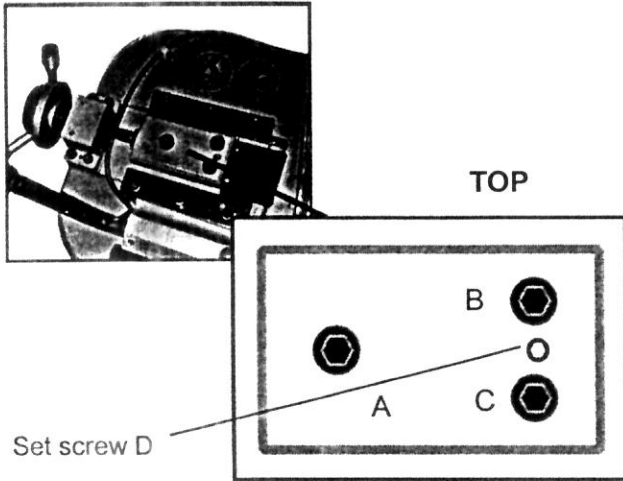

1. Loosen the hex nut screws A, B, and C.
 2. Use an Allen wrench on set screw D to adjust the tilt of the flywheel.
- Turning the set screw D clockwise will tilt flywheel so that the blade will ride closer to the flange.
 - Turning the set screw D counter-clockwise will tilt the flywheels that the blade will ride away from the flange. If the blade rides away too far then it will come off.

After the adjustment is finished, fasten the hex nut screws in this order: A, B, and C.

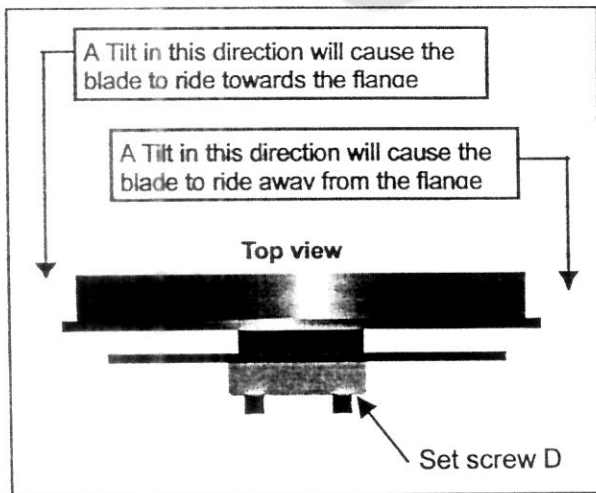

Checking the adjustment of the blade

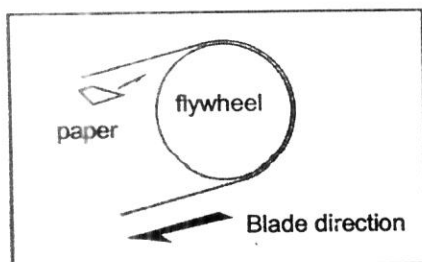

- Use a strip of scrap paper and slide it between the blade and the flywheel while it is running.
- if the paper is cut then the blade is riding too close to the flange. Re-adjust.
- if you notice that the blade is riding away from the flange. Then re-adjust.

WARNING: Always assemble blades having dimensions specified in this manual and for which the blade guide heads have been set; otherwise, see chapter on "Description of the operating cycle" in the section Starting-up.

6 ROUTINE AND SPECIAL MAINTENANCE

THE MAINTENANCE JOBS ARE LISTED BELOW, DIVIDED INTO DAILY, WEEKLY, MONTHLY AND SIX-MONTHLY INTERVALS. IF THE FOLLOWING OPERATIONS ARE NEGLECTED, THE RESULT WILL BE PREMATURE WEAR OF THE MACHINE AND POOR PERFORMANCE.

6.1 Daily maintenance

- General cleaning of the machine to remove accumulated shavings.
- Clean the lubricating coolant drain hole to avoid excess fluid.
- Top off the level of lubricating coolant.
- Check blade for wear.
- Rise of saw frame to top position and partial slackening of the blade to avoid useless yield stress.
- Check functionality of the shields and emergency stops.

6.2 Weekly maintenance

- Thorough cleaning of the machine to remove shavings, especially from the lubricant fluid tank.
- Removal of pump from its housing, cleaning of the suction filter and suction zone.
- Clean the filter of the pump suction head and the suction area.
- Use compressed air to clean the blade guides (guide bearings and drain hole of the lubricating cooling).
- Cleaning flywheel housings and blade sliding surfaces on flywheels.

6.3 Monthly maintenance

- Check the tightening of the motor flywheel screws.
- Check that the blade guide bearings on the heads are perfect running condition.
- Check the tightening of the screws of the gear motor, pump, and accident protection guarding.

6.4 Six-monthly maintenance

- Continuity test of the equipotential protection circuit.

6.5 Maintenance of other machine parts

The worm drive gearbox mounted on the machine is maintenance-free guaranteed by its manufacture.

6.6 Oils for lubricating coolant

Considering the vast range of products on the market, the user can choose the one most suited to their own

requirements, using as reference the type SHELL LUTEM OIL ECO. THE MINIMUM PERCENTAGE OF OIL DILUTED IN WATER IS 8 - 10 %.

6.7 Oil disposal

The disposal of these products is controlled by strict regulations. Please see the Chapter on "Machine dimensions Transport - Installation" in the section on *Dismantling*.

6.8 The gear box

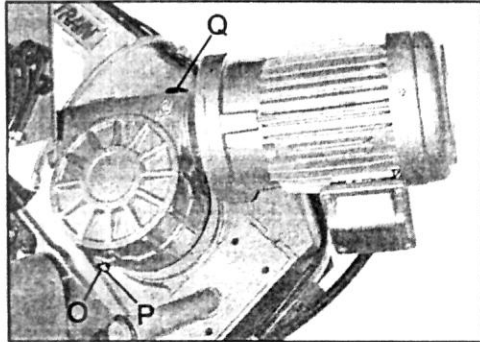

The gear box requires periodic changing of oil. The oil must be changed by the first 6 months of a new machine and every year thereafter.

To change the gear box oil

- Disconnect the machine from the power source.
- Raise the saw arm to vertical position
- Release the drain hold (O) to draw off gear oil by loosening the hex socket screw (P).

- Replace the screw (P) after oil completely flows off.
- Place the saw arm back to horizontal position.
- Fill Gear box with approximately .3 liter of gear oil through the hole of the vent screw (Q)

For reference, use SHELL type gear oil or Mobile gear oil #90.

6.9 Special maintenance

Special maintenance must be conducted by skilled personnel. We advise contacting your nearest dealer and/or importer. Also the reset of protective and safety equipment and devices (of the reducer), the motor, the motor pump, and other electrical components requires special maintenance.

7 TECHNICAL CHARACTERISTICS

7.1 Table of cutting capacity and technical details

CUTTING CAPACITY			
0°	227	220	260 X 110
45° DX (R)	150	145	200 X 125
60° DX (R)	90	85	
45° DX (L)	110	110	160 X 110

TYPES OF STEEL						CHARACTERISTICS		
USE	I UNI	D DIN	F AF NOR	GB SB	USA AISI-SAE	Hardness BRINELL HB	Hardness ROCKWELL HRB	R=N/mm²
Construction steels	Fe360	St37	E24	---	---	116	67	360÷480
	Fe430	St44	E28	43	---	148	80	430÷560
	Fe510	St52	E36	50	---	180	88	510÷660
Carbon steels	C20	CK20	XC20	060 A 20	1020	198	93	540÷690
	C40	CK40	XC42H1	060 A 40	1040	198	93	700÷840
	C50	CK50	---	---	1050	202	94	760÷900
	C60	CK60	XC55	060 A 62	1060	202	94	830÷980
Spring steels	50CrV4	50CrV4	50CV4	735 A 50	6150	207	95	1140÷1330
	60SiCr8	60SiCr7	---	---	9262	224	98	1220÷1400
Alloyed steels for hardening and tempering and for nitriding	35CrMo4	34CrMo4	35CD4	708 A 37	4135	220	98	780÷930
	39NiCrMo4	36CrNiMo4	39NCD4	---	9640	228	99	860÷1060
	41CrAlMo7	41CrAlMo7	40CADG12	905 M 39	---	232	100	930÷1130
Alloyed casehardening steels	18NiCrMo7	---	20NCD7	En 325	4320	232	100	760÷1030
	20NiCrMo2	21NiCrMo2	20NCD2	805 H 20	4315	224	98	690÷980
Alloyed for bearings	100Cr6	100Cr6	100C6	534 A 99	52100	207	95	690÷980
Tool steel	52NiCrMoKU	56NiCrMoV7C100K	---	---	---	244	102	800÷1030
	C100KU	C100W1	---	BS 1	S-1	212	96	710÷980
	X210Cr13KU	X210Cr12	Z200C12	BD2-BD3	D6-D3	252	103	820÷1060
	58SiMo8KU	---	Y60SC7	---	S5	244	102	800÷1030
Stainless steels	X12Cr13	4001	---	---	410	202	94	670÷885
	X5CrNi1810	4301	Z5CN18.09	304 C 12	304	202	94	590÷685
	X8CrNi1910	---	---	---	---	202	94	540÷685
	X8CrNiMo1713	4401	Z6CDN17.12	316 S 16	316	202	94	490÷685
Copper alloys Special brass Bronze	Aluminium copper alloy G-CuAl11Fe4Ni4 UNI 5275					220	98	620÷685
	Special manganese/silicon brass G-CuZn36Si1Pb1 UNI5038					140	77	375÷440
	Manganese bronze SAE43 - SAE430					120	69	320÷410
	Phosphor bronze G-CuSn12 UNI 7013/2a					100	56.5	265÷314
Cast iron	Gray pig iron G25					212	96	245
	Spheroidal graphite cast iron GS600					232	100	600
	Malleable cast iron W40-05					222	98	420

ELECTRIC MOTOR-BLADE ROTATION	kW	0.59 / 1.1
COOLING PUMP ELECTRIC MOTOR	kW	0.09
REDUCTION UNIT IN OIL BATH	l	40:1
FLYWHEEL DIAMETER	mm	295
BLADE DIMENSIONS	mm	2455x27x0.9
BLADE SPEED CUTTING	m/min	36 / 72
OPENING VICE	mm	260
SAW FRAME TILTING	°	40
WORKING TABLE HEIGHT	mm	900
MACHINE WEIGHT	kg	280

8 MATERIAL CLASSIFICATION AND CHOICE OF TOOL

Since the aim is to obtain excellent cutting quality, the various parameters such as hardness of the material, shape and thickness, transverse cutting section of the part to be cut, selection of the type of cutting blade, cutting speed and control of saw frame lowering.

These specifications must therefore be harmoniously combined in a single operating condition according to practical considerations and common sense, so as to achieve an optimum condition that does not require countless operations to prepare the machine when there are many variations in the job to be performed. The various problems that crop up from time to time will be solved more easily if the operator has a good knowledge of these specifications.

8.1 Definition of materials

The table above lists the characteristics of the materials to be cut. So as to choose the right tool to use.

8.2 Selecting blade

First of all the pitch of the teeth must be chosen, in other words, the number of teeth per inch (25,4 mm) suitable for the material to be cut, according to these criteria:

- Parts with a thin and/or variable section such as profiles, pipes and plate, need close toothing, so that the number of teeth used simultaneously in cutting is from 3 to 6;
- Parts with large transverse sections and solid sections need widely spaced toothing to allow for the greater volume of the shavings and better tooth penetration;
- Parts made of soft material or plastic (light alloys, mild bronze, Teflon, wood, etc.) also require widely spaced toothing;
- Pieces cut in bundles require combo tooth design.

8.3 Teeth pitch

As already stated, this depends on the following factors:

- **Hardness of the material**
- **Dimensions of the section**
- **Wall thickness.**

THICKNESS mm	Z CONTINUOUS TOOTH DESIGN	Z COMBO TOOTH DESIGN
TILL 1.5	14	10/14
FROM 1 TO 2	8	8/12
FROM 2 TO 3	6	6/10
FROM 3 TO 5	6	5/8
FROM 4 TO 6	6	4/6
MORE THAN 6	4	4/6

S = THICKNESS

SOLID Ø OR L mm	Z CONTINUOUS TOOTH DESIGN	Z COMBO TOOTH DESIGN
TILL 30	8	5/8
FROM 30 TO 60	6	4/6
FROM 40 TO 80	4	4/6
MORE THAN 90	3	3/4

Ø = DIAMETER L = WIDTH

8.4 Cutting and advance speed

The cutting speed (m/min) and the advance speed (cm²/min = area traveled by the disk teeth when removing shavings) are limited by the development of heat close to the tips of the teeth.

- The cutting speed is subordinate to the resistance of the material ($R = N/mm^2$), to its hardness (HRC) and to the dimensions of the widest section.
- Too high an advance speed (= lowering of the saw frame) tends to cause the disk to deviate from the ideal cutting path, producing non rectilinear cuts on both the vertical and the horizontal plane.

The best combination of these two parameters can be seen directly examining the chips.

Long spiral-shaped chips indicate ideal cutting.

Very fine or pulverized chips indicate lack of feed and/or cutting pressure.

Thick and/or blue chips indicate overload of the blade.

8.5 Blade running-in

When cutting for the first time, it is good practice to run in the tool making a series of cuts at a low advance speed (= 30-35 cm²/min on material of average dimensions with respect to the cutting capacity and solid section of normal steel with $R = 410-510 N/mm^2$). Generously spraying the cutting area with lubricating coolant.

8.6 Blade structure

Bi-metal blades are the most commonly used. They consist of a silicon-steel blade backing by a laser welded high speed steel (HHS) cutting edge. The type of stocks are classified in M2, M42, M51 and differ from each other because of their major hardness due to the increasing percentage of Cobalt (Cc) and molybdenum (Mo) contained in the metal alloy

8.7 Blade type

They differ essentially in their constructive characteristics, such as:

- Shape and cutting angle of tooth
- Pitch
- Set

Shape and angle of tooth

REGULAR TOOTH: 0° rake and constant pitch.



Most common form for transversal or inclined cutting of solid small and average cross-sections or pipes, in laminated mild steel and gray iron or general metal.

POSITIVE RAKE TOOTH: 9° - 10° positive rake and constant pitch.

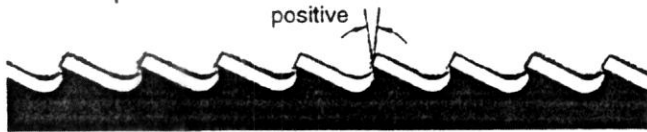

Particular use for crosswise or inclined cuts in solid sections or large pipes, but above all harder materials (highly alloyed and stainless steels, special bronze and forge pig iron).

COMBO TOOTH: pitch varies between teeth and consequently varying teeth size and varying gullet depths. Pitch varies between teeth, which ensures a smoother, quieter cut and longer blade life owing to the lack of vibration.

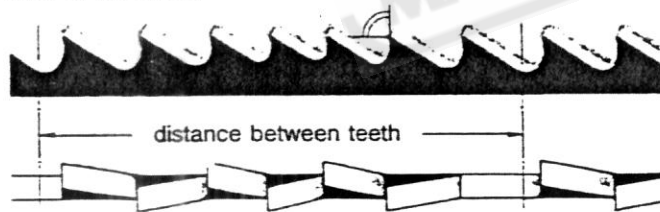

Another advantage offered in the use of this type of blade in the fact that with an only blade it is possible to cut a wide range of different materials in size and type.

COMBO TOOTH: 9° - 10° positive rake.

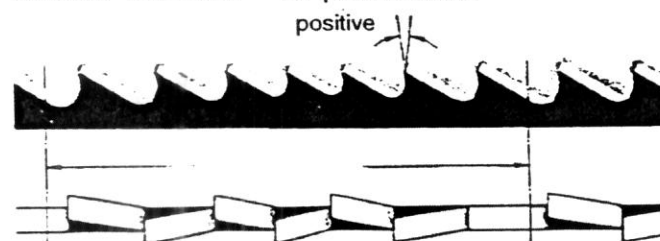

9 NOISE TESTS

The test was held under environmental noise levels of 65db. Noise measurements with the machine operating unload was 71db. Noise level during the cutting of mild carbon steel was 73db.

NOTE: with the machine operating, the noise level will vary according to the different materials being processed. The user must therefore assess the intensity and if necessary provide the operators with the necessary personal protection, as required by Law 277/1991.

This type of blade is the most suitable for the cutting of section bars and large and thick pipes as well as for the cutting of solid bars at maximum machine capacity. Available pitches: 3-4/4-6.

SETS

Saw teeth bent out of the plane of the saw body, resulting in a wide cut in the workpiece.

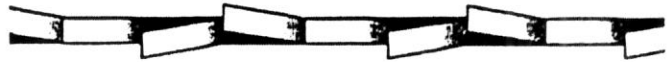

REGULAR OR RAKER SET: Cutting teeth right and left, alternated by a straight tooth.

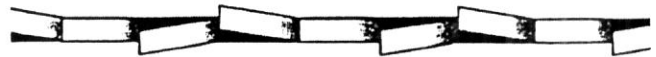

Of general use for materials with dimensions superior to 5 mm. Used for the cutting of steel, castings and hard nonferrous materials.

WAVY SET: Set in smooth waves.



This set is associated with very fine teeth and it is mainly used for the cutting of pipes and thin section bars (from 1 to 3 mm).

ALTERNATE SET (IN GROUPS): Groups of cutting teeth right and left, alternated by a straight tooth.



This set is associated with very fine teeth and it is used for extremely thin materials (less than 1mm).

ALTERNATE SET (INDIVIDUAL TEETH): Cutting teeth right and left.



This set is used for the cutting of nonferrous soft materials, plastics and wood.

11 TROUBLESHOOTING

This chapter lists the probable faults and malfunctions that could occur while the machine is being used and suggests possible remedies for solving them.

The first paragraph provides diagnosis for TOOLS and CUTS the second for ELECTRICAL COMPONENTS.

11.1 - Blade and cut diagnosis

FAULT

TOOTH BREAKAGE

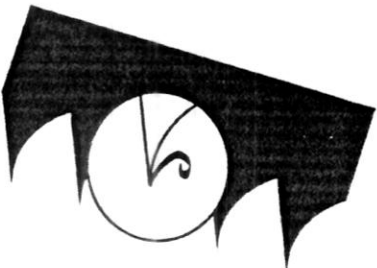

PROBABLE CAUSE

Too fast advance

Wrong cutting speed

Wrong tooth pitch

Chips sticking onto teeth and in the gullets or material that gums

Defects on the material or material too hard

Ineffective gripping of the part in the vice

The blade gets stuck in the material

Starting cut on sharp or irregular section bars

Poor quality blade

Previously broken tooth left in the cut

Cutting resumed on a groove made previously

Vibrations

Wrong tooth pitch or shape

Insufficient lubricating, refrigerant, or wrong emulsion

Teeth positioned in the direction

REMEDY

Decrease advance, exerting less cutting pressure. Adjust the braking device.

Change speed and/or type of blade. See chapter on "Material classification and blade selection", in the section *Blade selection table* according to cutting and feed speed.

Choose a suitable blade. See Chapter "Material classification and blade selection".

Check for clogging of coolant drain holes on the blade-guide blocks and that flow is plentiful in order to facilitate the removal of chips from the blade.

Material surfaces can be oxidized or covered with impurities making them, at the beginning of the cut, harder than the blade itself, or have hardened areas or inclusions inside the section due to productive agents used such as casting sand, welding wastes, etc. Avoid cutting these materials or in a situation a cut has to be made use extreme care, cleaning and remove any such impurities as quickly as possible.

Check the gripping of the part.

Reduce feed and exert less cutting pressure.

Pay more attention when you start cutting.

Use a superior quality blade.

Accurately remove all the parts left in.

Make the cut elsewhere, turning the part.

Check gripping of the part.

Replace blade with a more suitable one. See "Material classification and blade selection" in the *Blade Types* section. Adjust blade guide pads.

Check level of liquid in the tank. Increase the flow of lubricating refrigerant, checking that the hole and the liquid outlet pipe are not blocked. Check the emulsion percentage.

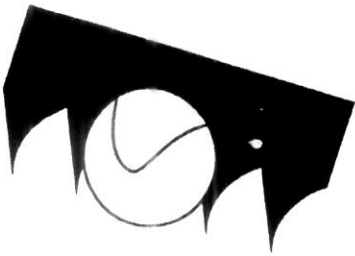
FAULTPROBABLE CAUSEREMEDY**PREMATURE BLADE WEAR**

Faulty running-in of blade

Teeth positioned in the direction opposite the cutting direction

Poor quality blade

Too fast advance

Wrong cutting speed

Defects on the material or material too hard

Insufficient lubricating refrigerant or wrong emulsion

See **"Material classification and blade selection"** in the *Blade running-in* section.

Turn teeth in correct direction.

Use a superior quality blade.

Decrease advance, exerting less cutting pressure. Adjust the braking device.

Change speed and/or type of blade. See chapter on **"Material classification and blade selection"**, in the section *Blade selection table according to cutting and feed speed*.

Material surfaces can be oxidized or covered with impurities making them, at the beginning of the cut, harder than the blade itself, or have hardened areas or inclusions inside the section due to productive agents used such as casting sand, welding wastes, etc. Avoid cutting these materials or perform cutting with extreme care, cleaning and remove such impurities as quickly as possible.

Check level of liquid in the tank. Increase the flow of lubricating coolant, checking that the coolant nozzle and pipe are not blocked. Check the emulsion percentage.

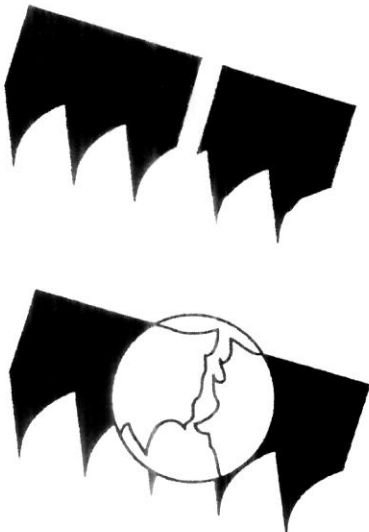
BLADE BREAKAGE

Faulty welding of blade

Too fast advance

Wrong cutting speed

Wrong tooth pitch

Ineffective gripping of the part in the vice

Blade touching material at beginning of cut

Remedy

The welding of the blade is of utmost importance. The meeting surfaces must perfectly match and once they are welded they must have no inclusions or bubbles; the welded part must be perfectly smooth and even. They must be evenly thick and have no bulges that can cause dents or instant breakage when sliding between the blade guide pads.

Decrease advance, exerting less cutting pressure. Adjust the braking device.

Change speed and/or type of blade.

See chapter on **"Material classification and blade selection"**, in the section *Blade selection table according to cutting and feed speed*.

Choose a suitable blade. See Chapter **"Material classification and blade selection"**.

Check the gripping of the part.

At the beginning of the cutting process, never lower the saw arm before starting the blade motor.

FAULT

PROBABLE CAUSE

REMEDY

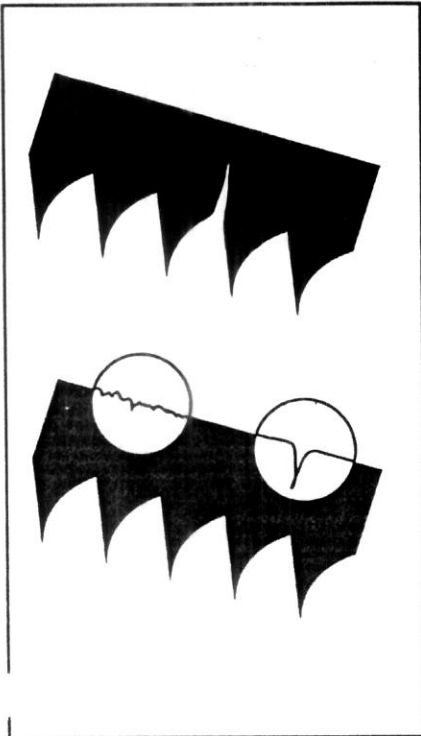

Blade guide pads not regulated or dirty because of lack of maintenance

Blade guide block too far from material to be cut

Improper position of blade on flywheels

Insufficient lubricating coolant or wrong emulsion

Check distance between pads (see **"Machine adjustments"** in the *Blade Guide Blocks* section): extremely accurate guiding may cause cracks and breakage of the tooth. Use extreme care when cleaning.

Approach head as near as possible to material to be cut so that only the blade section employed in the cut is free, this will prevent deflections that would excessively stress the blade.

The back of blade rubs against the support due to deformed or poorly welded bands (tapered), causing cracks and swelling of the back contour.

Check level of liquid in the tank. Increase the flow of lubricating refrigerant, checking that the hole and the liquid outlet pipe are not blocked. Check the emulsion percentage.

STEAKED OR ETCHED BANDS

Damaged or chipped blade guide pads

Tight or slackened blade guide bearings.

Replace them.

Adjust them (see Chapter **"Machine adjustments"** in *Blade guide* section).

CUTS OFF THE STRAIGHT

Blade not parallel as to the counter service

Blade not perpendicular due to the excessive play between the guide pads and maladjustment of the blocks

Too fast advance

Worn out blade

Wrong tooth pitch

Check fastenings of the blade guide blocks as to the counter-vice so that they are not too loose and adjust blocks vertically; bring into line the position of the degrees and if necessary adjust the stop screws of the degree cuts.

Check and vertically re-adjust the blade guide blocks; reset proper side guide play (see Chapter **"Machine adjustments"** in *Blade guide* section).

Decrease advance, exerting less cutting pressure. Adjust the braking device.

Approach it as near as possible to material to be cut so that only the blade section employed in the cut is free, this will prevent deflections that would excessively stress the blade.

Replace it. Blade with major density of teeth is being used, try using one with less teeth (see Chapter **"Material classification and blade selection"** in the *Blade Types* section).

FAULTPROBABLE CAUSEREMEDY

	<p>Broken teeth</p> <p>Insufficient lubricating refrigerant or wrong emulsion</p>	<p>Irregular work of the blade due to the lack of teeth can cause deflection in the cut; check blade and if necessary replace it.</p> <p>Check level of liquid in the tank. Increase the flow of lubricating coolant, checking that the hole and the liquid outlet pipe are not blocked. Check the emulsion <i>percentage</i>.</p>
<p>FAULTY CUT</p>	<p>Worn out flywheels Flywheel housing full of chips</p>	<p>The support and guide flange of the band are so worn out that they cannot ensure the alignment of the blade, causing faulty cutting; blade rolling and drawing tracks can have become tapered. Replace them. Clean with compressed air.</p>
<p>STREAKED CUTTING SURFACE</p> 	<p>Too fast advance</p> <p>Poor quality blade</p> <p>Worn out blade or with chipped and/or broken teeth</p> <p>Wrong tooth pitch</p> <p>Blade guide block too far from material to be cut</p> <p>Insufficient lubricating coolant or wrong emulsion</p>	<p>Decrease advance, exerting less cutting pressure. Adjust the braking device.</p> <p>Use a superior quality blade.</p> <p>Replace it.</p> <p>Blade used probably has too large teeth, use one with more teeth (see "Material classification and blade selection" in the <i>Blade Types</i> section).</p> <p>Approach it as near as possible to material to be cut so that only the blade section employed in the cut is free, this will prevent deflections that would excessively stress the blade.</p> <p>Check level of liquid in the tank. Increase the flow of lubricating coolant, checking that the hole and the liquid outlet pipe are not blocked. Check the emulsion <i>percentage</i>.</p>
<p>NOISE ON GUIDE BLOCKS</p>	<p>Chipped bearings Worn out or damaged pads</p>	<p>Dirt and/or chips between blade and guide bearings. Replace them. Replace them.</p>

11.2 - Electrical components diagnosis

FAULT

PROBABLE CAUSE

REMEDY

<p>THE BAND ROTATION MOTOR DOES NOT WORK</p>	<p>"SA1" two-speed switch</p> <p>"FR1" band motor over-load relay</p> <p>"SB1" emergency switch</p> <p>"SA2" start push button</p>	<p>It must be exactly turned towards Rabbit or Turtle sign.</p> <p>Push down FR1 red button. After a motor cooling time of 5 minutes, if there is no current continuity on these two wires, the motor must be replaced.</p> <p>Reset emergency switch (see operation procedure).</p> <p>Check the functioning and/or possible damages. If so, replace it.</p>
<p>MACHINE DOES NOT WORK</p>	<p>Fuses "FU"</p> <p>"SQ1" Automatic shutoff limit switch</p> <p>"SQ2" blade cover limit switch</p> <p>"SQ3" blade broken limit switch</p> <p>Speed switch "SA1" in position "0"</p> <p>Emergency button "SB1" on</p> <p>"SB2" trigger switch</p> <p>Motor "M1"</p>	<p>Check electrical efficiency. If not, replace the fuse.</p> <p>Refer to the operation procedure and adjust the switch if machine doesn't shut off after the material completely cuts. Replace it if it damaged.</p> <p>Check closing of the fly wheel cover. Check the efficiency of the device; replace it if damaged.</p> <p>Check the efficiency of the device; replace it if damaged.</p> <p>It must be exactly turned to Rabbit or Turtle sign.</p> <p>Reset the emergency switch by following the steps of Operation Procedure. Check electrical efficiency, if not, replace it.</p> <p>Check the efficiency of the device; replace it if damaged.</p> <p>Check current continuity on the two wires in the prone, if not, replace the motor.</p>
<p>MOTOR STOPPED WITH PILOT LIGHT "HL2" LIT</p>	<p>"SB2" trigger switch</p> <p>Motor "M 1"</p>	<p>Check the efficiency of the device; replace it if damaged.</p> <p>Check that it is not burnt and that it turns freely. Replace it if damaged.</p>

12 MACHINE COMPONENTS

12.1 PART LIST

Part No.	Description	Size No.	Q'ty	Part No.	Description	Size No.	Q'ty
1	Base (Bottom Plate)		1	63	Locking Lever		1
2	Base (Left Part)		1	63-1	Set Screw	M10X10	1
2-1	Nut	M8	2	64	Hex. Socket Cap Screw	M10X35	1
3	Base (Right Part)		1	64-1	Spring Washer	M10	1
4	Base (Front Part)		1	65	Shaft Nut		1
4-1	Hex. Cap Bolt	M8X16	2	66	Shaft		1
5	Hex. Cap Bolt	M12X40	2	67	Key	7X7X40	1
6	Nut	M12	2	68	Swivel Arm		1
8	Hex. Cap Bolt	M8X12	6	68-1	Hex. Cap Bolt	M10X35	1
8-1	Washer	M8	6	69	Scale		1
9	Plate		1	70	Rivet	2m/m	3
10	Hex. Socket Cap Screw	M5X8	4	71	Pin		1
11	Coolant Tank		1	72	Hollow Pin	Ø 2.5	1
12	Hex. Cap Bolt	M8X12	2	73	Spring		1
13	Coolant Gauge		1	74	Bushing		1
14	Hex. Cap Bolt	3/16"	2	75	Bracket		1
15	Tank Cover		1	76	Spring Washer	M8	2
16	Filter		1	77	Hex. Socket Cap Screw	M8X25	2
17	Pump (New)		1	78	Nut		1
18	Hex. Cap Bolt	M8X16	2	79	Jam Nut	M35	1
18-1	Washer	M8	2	80	Star Washer	Ø 35	1
22	Hose Clamp		1	81	Anti-Dust Cover	Ø 35 (32007AV)	2
23	Hose	5/16" X235cm	1	82	Ball Bearing	32007	2
23-1	Hose	1" X45cm	1	83	Shaft		1
24	Coolant and Chip Tray		1	84	Hex. Cap Bolt	M10X45	1
25	Mounting Bracket		2	85	Nut	M10	2
26	Spring Washer	M10	4	86	Pointer		1
27	Hex. Socket Cap Screw	M10X20	4	87	Hex. Socket Cap Screw	M5X8	2
28	Flat Washer	M10	2	88	Cover		1
29	Hex. Cap Bolt	M10X20	4	88-1	Hollow Pin	Ø 6	2
30	Hex. Cap Bolt	M12X40	2	89	Hex. Socket Cap Screw	M8X35	3
31	Nut	M12	2	89-1	Spring Washer	M8	3
36	Emergency Switch	Ø 25	1	90	Flat Washer	M10	1
39	Track		1	91	Hex. Socket Cap Screw	M10X20	1
40	Hex. Socket Cap Screw	M8X35	2	91-1	Spring Washer	M10	1
40-1	Nut	M8	2	92	Table		1
41	Set Screw	M6X12	4	92-1	Set Screw	M6X12	1
42	Flat Washer		1	93	C-Ring	S-20	1
43	Handle	M8X20	1	94	Bar-Stop-Rod		1
44	Roller Stand		1	95	Bar-Stop		1
45	Hex. Cap Bolt	M12X25	2	96	Handle		1
46	Spring Washer	M12	2	97	Scale		1
46-1	Flat Washer	M12	2	98	Rivet	2m/m	3
47	Roller		1	99	Chip Gutter		1
48	Ball Bearing	6004 ZZ#	2	100	Hex. Socket Cap Screw	M6X8	2
48-1	C-Ring	S-20	2	102	No-Burr Jaw		1
49	Roller Shaft		1	103	Hex. Socket Cap Screw	M6X20	2
50	Hex. Socket Cap Screw	M10X25	2	104	Counter Vise Jaw		1
60	Handle		1	105	Hex. Socket Cap Screw	M6X20	2
60-1	Hex. Socket Cap Screw	M8X20	2	106	Vise Jaw		1
60-2	Nut	M8	2	107	Flat Head Machine Screw	M6X15	2
61	Handle		1	108	Vise		1
62	Nut	M12	1	109	Dovetail Plate		1

PART LIST

Part No.	Description	Size No.	Q'ty	Part No.	Description	Size No.	Q'ty
110	Nut	M5	3	150-2	Spring Washer	M8	4
111	Set Screw	M5X25	3	151	Reduction Unit		1
113	Key	5X5X20	1	151-1	Vent Screw		1
115	Spring Washer	M8	4	152	Key	8X8X30	1
116	Hex. Socket Cap Screw	M8X25	4	153	Hex. Cap Bolt	M8X30	4
117	Hand Wheel		1	153-1	Spring Washer	M8	4
117-1	Spring Washer	M6	1	154	Motor		1
117-2	Hex. Socket Cap Screw	M6X25	1	155	Key	8X8X30	1
117-3	Bushing		1	186	Hex. Socket Cap Screw	M10X40	4
118	Set Screw	M8X10	1	186-1	Spring Washer	M10	4
119	Treaded Nut		1	193A	Saw Arm		1
120	Vise Seat		1	193-1	Set Screw	M8X30	2
121	Hex. Socket Cap Screw	M8X20	4	194	Hex. Socket Cap Screw	M10X30	4
121-1	Spring Washer	M8	4	194-1	Spring Washer	M10	4
122	Vise Setting Plate		1	195	Limit Switch		1
123	Hex. Socket Cap Screw	M10X35	2	195-1	Switch Pin		1
124	Setting Washer		1	196	Hex. Socket Cap Screw	M4X35	2
125	Setting Screw		1	197	Hex. Socket Cap Screw	M10X40	4
126	Setting Bolt		1	197-1	Spring Washer	M10	4
127	Handle		1	198	Pipe Fitting Seat		1
128	Setting Plate		1	199	Hex. Socket Cap Screw	M5X30	2
129	Bushing		1	200	Coolant Switch		1
130	Hex. Socket Cap Screw	M8X20	2	201	Hose Clamp		1
130-1	Spring Washer	M8	2	203	Pipe Fitting	1/4PX5/16	2
131	Electric Box Holder		1	204	Hose	5/16"X40cm	1
132	Spring Washer	M8	4	205	Hose	5/16"X90cm	1
133	Hex. Socket Cap Screw	M8X20	4	206	Drive Flywheel		1
135	Hex. Socket Cap Screw	M10X35	2	207	Washer		1
136	Spring Washer	M10	2	207-1	Spring Washer	M10	1
138	Hex. Socket Cap Screw	M6X25	2	208	Hex. Cap Bolt	M10X20	1
139	Nut	M6	2	209A	Idle Flywheel Shaft		1
142	Hex. Socket Cap Screw	M5X8	10	210	Roller Bearing	32006	2
143	Nut	M5	4	211	Idle Flywheel		1
144	Electric Box Platform		1	212	Star Washer	∅30	1
144-1	Transformer		1	212-1	Anti-dust Cover	∅30 (32006AV)	2
144-2	Fuse Block	2A	1	213	Jam Nut	M30	1
144-3	Magnetic Switch		1	214	Oil Inlet	1/16	1
144-4	Overload Relay	6.5A	1	215	Saw Blade		1
144-5	Terminal Strip		1	216	Blade Cover		1
144-6	Insulation Plate		1	216-1	Gutter		1
144-7	Electric Parts Plate		1	216-2	Round Head Screw	M5X6	3
146	Hex. Socket Cap Screw	M5X8	4	217	Plum Screw	M6X10	4
147-1	Indicator Light		1	219	Round Head Screw	M4X8	2
147-2	Main Connect Switch		1	220	Nut	M4	2
147-5	Speed Selector		1	220-1	Spring Washer	M4	2
147-6	Start Push Button		1	222	Handle		2
147-7	Manual/ Auto Selector		1	223	Handle Wheel		1
147-8	Control Panel		1	224	Special Spring Washer		10
148	Electrical Box Cover		1	225	Tension Shaft		1
149	Supporting Bracket		1	229	Plate		1
149-1	Shaft		1	230	Hex. Socket Cap Bolt	M6X12	2
150	Set Screw	M6X12	1	231	Limit Switch		1
150-1	Hex. Socket Cap Screw	M8X25	4	232	Hex. Socket Cap Bolt	M4X15	2

PART LIST

Part No.	Description	Size No.	Q'ty	Part No.	Description	Size No.	Q'ty
233A	Tension Indicator Stand		1	285	Washer	M6	2
234	Hex. Socket Cap Bolt	M5X8	2	286	Lead Screw		1
235	Tension Indicator		1	286-1	Spring		1
236	Round Head Screw	M4X6	2	287	Setting Seat		1
237	Indicator Cover		1	288	Lead Screw Seat		1
238	Set Screw	M5X5	1	289	Bearing Bushing		1
239	Nut	M16	1	289-1	Ball Bearing	50014	1
240A	Slide Bracket		1	289-2	Nut		1
240A-1	Spring Washer	M12	3	291	Switch Body		1
240A-2	Hex. Socket Cap Screw	M12X50	3	291-1	Trigger		1
240A-3	Set Screw	M10X16	1	291-2	Compressed Spring		2
244	Cover Plate		1	291-3	Set Bushing		1
245	Hex. Socket Cap Screw	M6X8	2	291-4	Flat Head Machine Screw	M3X8	2
246	Gib		2	291-5	Limit Switch		1
247	Spring Washer	M8	6	291-6	Cover		1
248	Hex. Socket Cap Screw	M8X25	6	291-7	Tapping Screw	M3X10	4
249	Blade Guide Movable Rod		1	292	Pipe		1
249-1	Hex. Socket Cap Screw	M6X8	1	292-1	Nut		1
250	Set Screw	M6X12	4	293	Nut	M8	1
251	Hex. Socket Cap Screw	M8X25	2	294	Spring Hook		1
252	Setting Bracket		1	295	Spring		1
253	Hex. Socket Cap Screw	M12X50	1	296	Spring Seat		1
254	Handle		1	297	Spring Bushing		1
256	Guide Bracket		1	298	C-Ring	S-12	4
257	Nozzle		1	298-1	Flat Washer		2
258	Nut	M8	1	299	Shaft		1
259	Set Screw	M10X35	1	300	Pin		1
260	Hex. Socket Cap Screw	M6X8	1	301	Hollow Pin	Ø2.5X16	1
261	Blade Guard		1	302	Spring		1
262	Set Screw	M6X20	2	303	Fork		1
263	Nut	M6	2	304	Nut	M10	1
264	Centric Shaft		2	305	Adjusting Bracket		1
265	Ball Bearing	#608ZZ	8	306	Shaft		1
265-1	Ball Bearing	#608ZZ	2	307	Knob		1
266	E-Ring	Ø7	8	307-1	Bushing		1
267	Blade Guide		2	308	Shaft		1
268	Hex. Socket Cap Screw	M6X25	2	309	Arm		1
269	Eccentric Shaft		2	310	C-Ring	S-12	2
270	Hex. Socket Cap Screw	M6X8	2	311	Hex. Socket Cap Screw	M10X20	1
271	Blade Guard		1	312	Spring Washer	M10	1
272	Guide Bracket		1	313	Post		1
272-1	Hex. Socket Cap Screw	M6X8	2	314	Set Screw	M10X10	2
273	Pipe Fitting		1	315	Hydraulic Cylinder Post		1
274	Blade Guide		2	316	Spring Washer	M8	4
275	Ball Bearing Bracket		1	317	Hex. Socket Cap Screw	M8X25	4
276	Set Screw	M6X12	4	318	Hex. Socket Cap Screw	M4X25	2
277	Hex. Socket Cap Screw	M10X30	2	319	Limit Switch		1
279	Hex. Socket Cap Screw	M8X25	2	320	Set Screw	M6X12	1
280	Brush		1	321	Setting Plate		1
281	Brush Clamp		1	322	Hydraulic Cylinder		1
282	Set Screw	M5X5	1	323	Hex. Socket Cap Screw	M10X40	1
283	Set Bushing		1	324	Nut	M10	1
284	Hex. Cap Screw	M6X12	2				

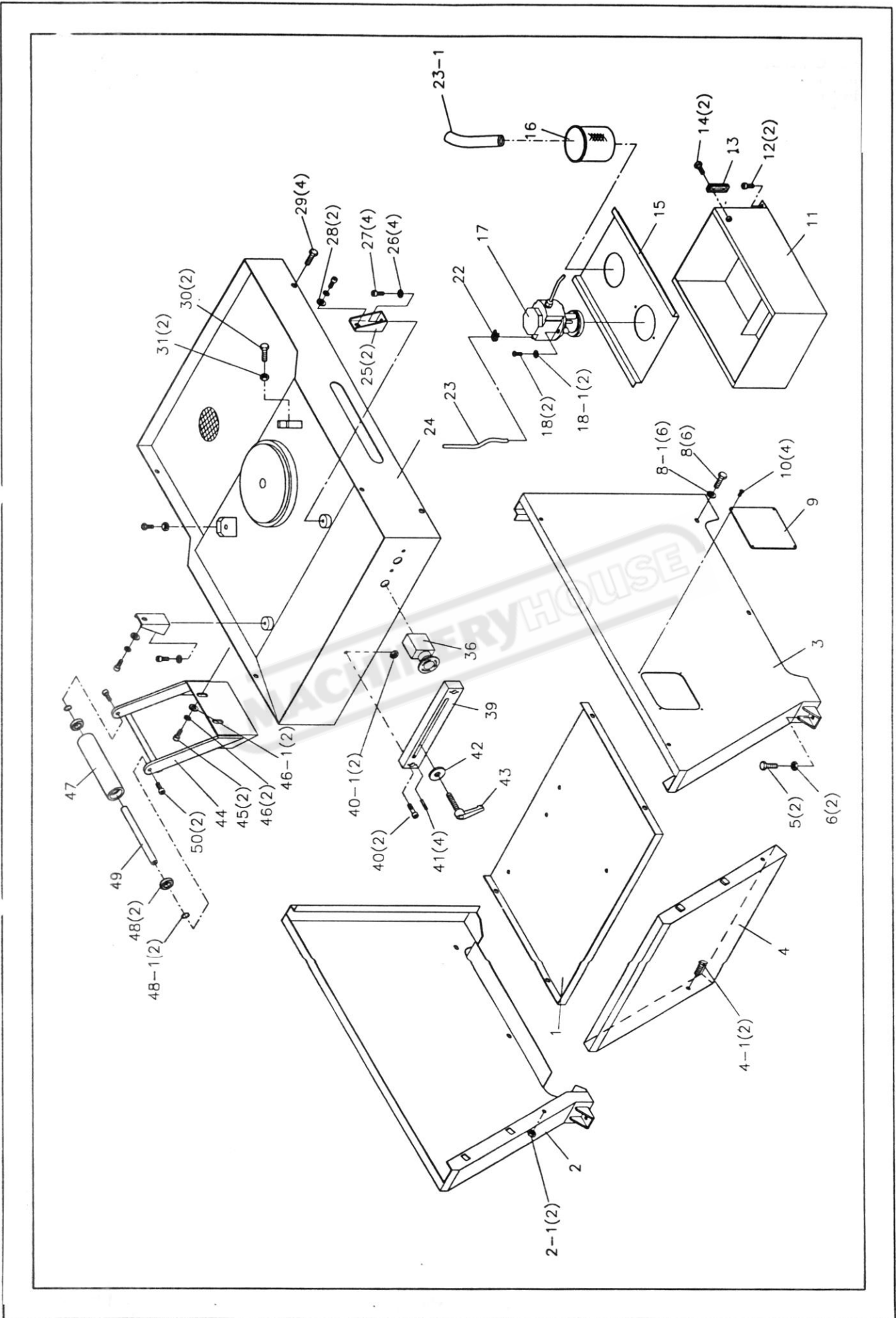

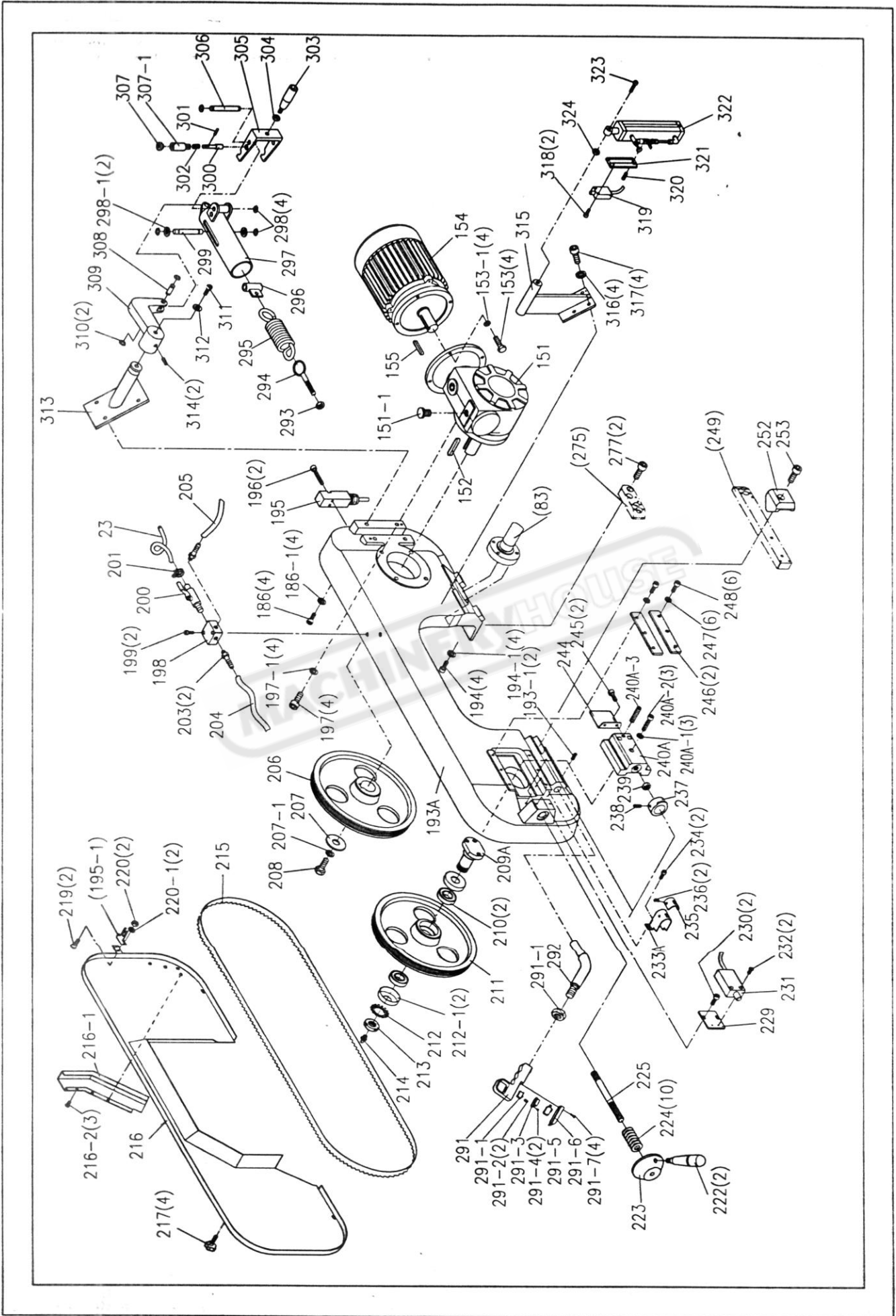

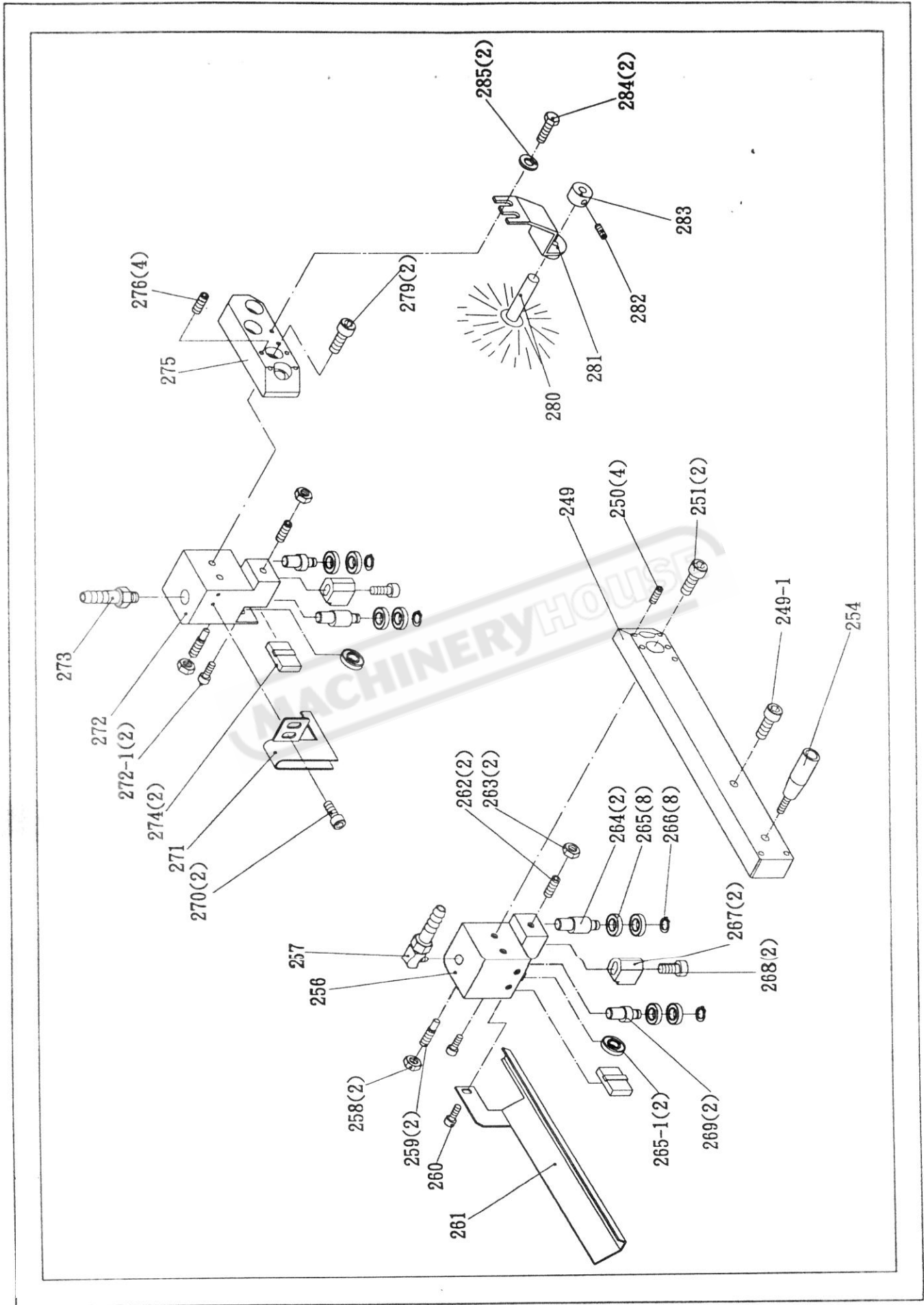

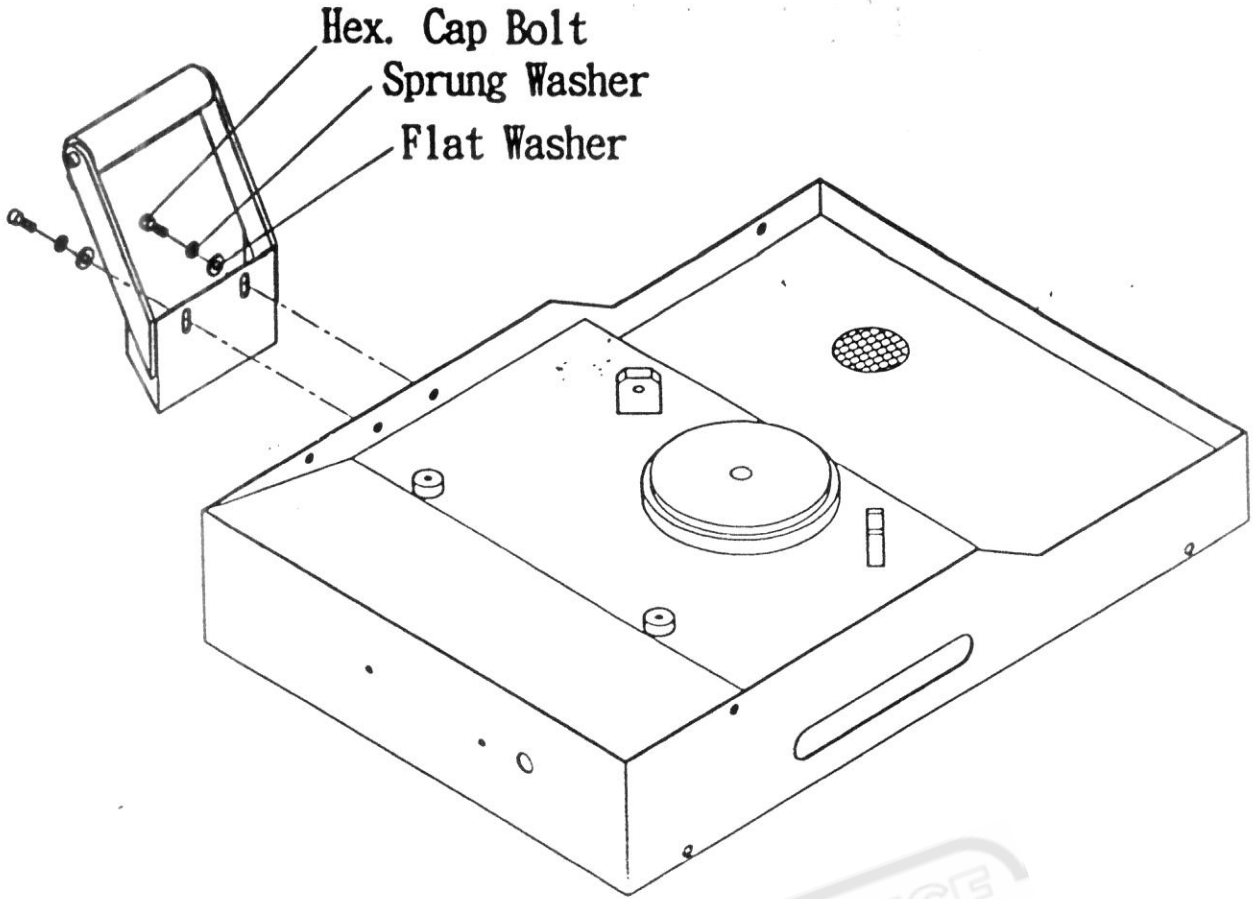

MACHINERYHOUSE

Round Head Screw

Gutter

